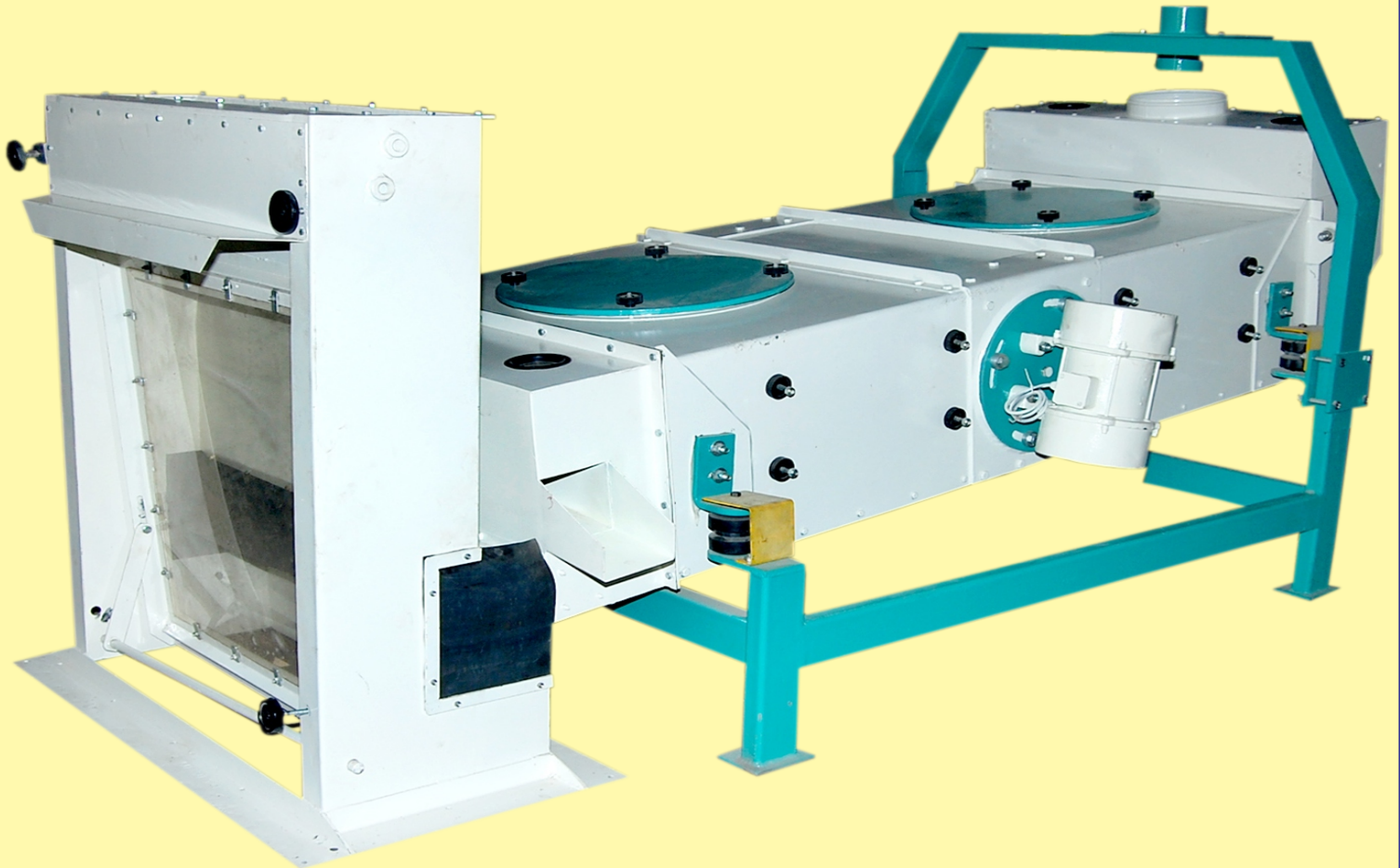

**PREMIUM**

# FINE PRE-CLEANER

  
(CLASSIFIER)**(FOR EFFICIENT CLEANING OF GRAIN FOR DISTILLERY MILL)**

## SALIENT FEATURES

- ▶ Removes immatured Grains alongwith other impurities
- ▶ Inbuilt Cleaning System to avoid clogging of Screen
- ▶ Different Screens can be mounted to suit the applications
- ▶ Screens can be interchanged easily
- ▶ No relatively moving parts
- ▶ Less maintenance
- ▶ Free swinging sieve with unidirectional screen motion support on hollow rubber springs
- ▶ Driven by Vibrators
- ▶ Adjustable Angle of Throw
- ▶ Adjustable stroke
- ▶ Screen inclination preset at the works made to suit the place of application adjustment

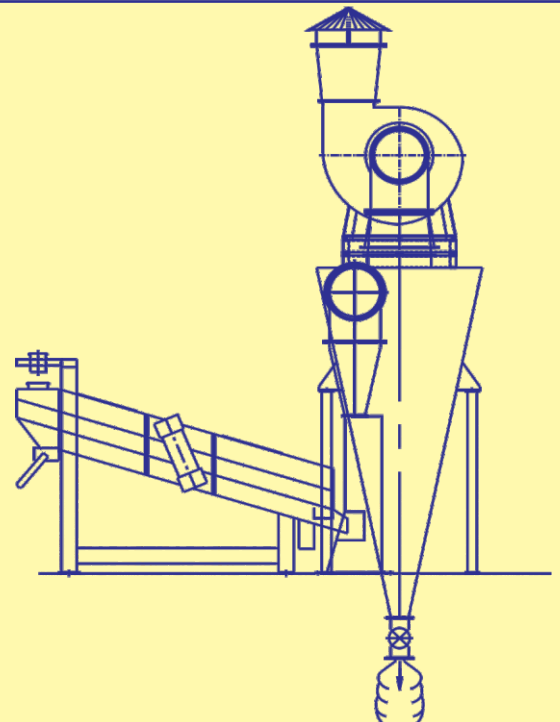

Machine with Cyclone, Blower & Rotary Valve

# General Description

“ PREMIUM ’ FINE PRE - CLEANER is for preliminary cleaning of all kinds of grains in milling plants, brewery and silo system. This machine is suitable for all kind of grains such as sorghum , wheat , Rice , soyabean , mustard etc. The powerful aspiration system situated at the side of the machine effectively removes light impurity and dust. Further the vibrating sieve removes stones, lumps of clay and other bigger impurities.

## Working Principles

The grain cleaner is a combination of robust heavy duty grader and a powerful aspiration system. Material fed at the inlet passes through sieves which remove coarse and fine impurities. The clean material falls in the post aspiration chamber where the remaining dust particle and light impurities are removed by means of a powerful air current. Finally the clean grain is received at the outlet. The aspiration system comprises blower, Cyclone, Rotary Air Lock Valve and Dust Collector.

## TECHNICAL SPECIFICATIONS

MODEL	CAPACITY MT/HR.	MOTOR H.P.			SCREEN SIZE (in mm)	Approx. OVERALL DIMENSIONS (In mm)		
		MACHINE	BLOWER	ROTARY VALVE		L	W	H
PFPC - 02	2	0.5 + 0.5	5	1	1000X1200	2100	1500	1500
PFPC - 04	4	1 + 1	7.5	1	1000X2000	2900	1500	1500
PFPC - 06	6	1.5 + 1.5	10	1	1500X2000	2900	2000	1800
PFPC - 08	8	1.5 + 1.5	10	1	1700X2000	2900	2200	1800
PFPC - 10	10	2 + 2	15	1	1800X2000	2900	2300	2000
PFPC - 12	12	2 + 2	20	1	2000X2000	2900	2500	2200

Specification & designs are subject to change without notice for any additional improvement.

Above Capacities are for GRAIN of 0.75 gram/cc. Bulk Density.

## ALSO AVAILABLE OTHER CLEANING EQUIPMENT

**SCREEN AIR SEPARATOR**  
(Preliminary Cleaner)



**DESTONER**  
(Vacuum Type)



**MAGNETIC SEPARATOR**  
(Drum Type)



Designed, Manufactured & Supplied by :

**PREMIUM  
PULMAN PVT LTD**

Plot No. 2009, Phase-IV, GIDC Industrial Estate, Vatva, Ahmedabad - 382 445. INDIA

Phone : (079) 25894693, 25832541 Fax : (079) 25830965

E-mail : [exports@premiumpulverisers.com](mailto:exports@premiumpulverisers.com), [premiumpulman@gmail.com](mailto:premiumpulman@gmail.com)

Visit us : [www.premiumpulverisers.com](http://www.premiumpulverisers.com) / [www.premiumpulman.com](http://www.premiumpulman.com)

PROFESSIONALS IN SIZE REDUCTION TECHNOLOGY



PREMIUM